

4

3

2

1

REVISION HISTORY					
ZONE	SHEET	REV.	DESCRIPTION	DATE	APPROVED
	ALL	A	INITIAL RELEASE	19/04/22	KJK
C4		B	ADDED MATERIAL CALLOUT	22MAY19	JMD
	ALL	C	ADDED ADDITIONAL DIMENSIONS. ADDED NOTE 8	01NOV2019	JMD

NOTES:

1. APPLICABLE STANDARDS/SPECIFICATIONS:
ASME Y14.5M-1994 DIMENSIONS AND TOLERANCES
2. SQUARE PLATE PATTERN FOLLOWS VESA MIS-D, 100.
3. MOUNT PLATE TO WALL OR MOUNTING SURFACE WITH DESIRED SCREW PATTERN.
4. SCREWS MAY NOT SIT FLUSH. THIS WILL NOT IMPACT PERFORMANCE OR FIT.
5. AFTER SECURING PLATE, HANG UNIT BY UPPER BOLTS ON U-SHAPED RESTING SURFACES ON THE PLATE.
6. SECURE UNIT WITH PROVIDED SCREWS AND KEY VIA SIDE SCREW MOUNTS. NOTE THAT THE UNIT WILL NEED TO BE TILTED SLIGHTLY TO BE PARALLEL WITH PLATE AND LINE UP AFOREMENTIONED SCREWS.
7. MATERIAL: MAKROLON 6485, BLACK
8. DIMENSIONS ARE IN MM. BRACKETED DIMENSIONS ARE IN [INCHES]

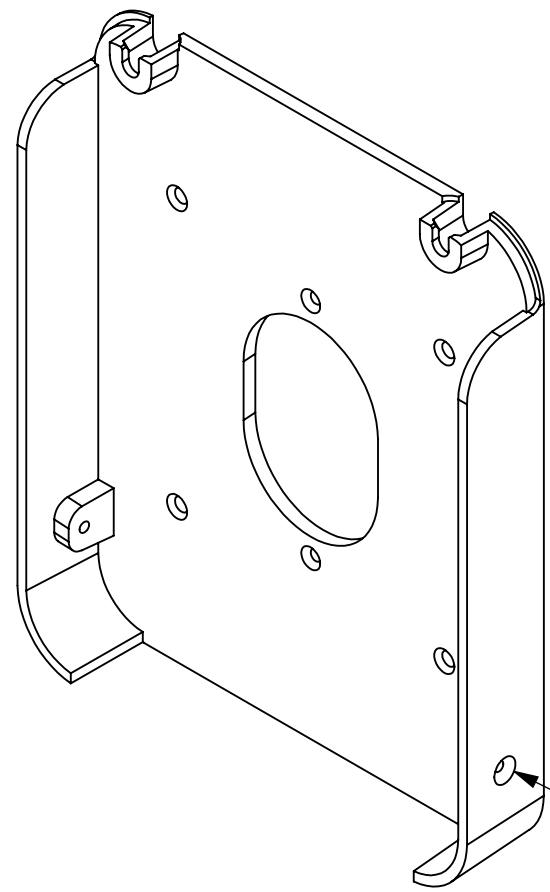

2X COUNTERSUNK M3 TAMPER-RESISTANT HEX SCREWS AND KEY INCLUDED

SCALE: 1:2

4X COUNTERSUNK M4 OR #8 (NOT INCLUDED)

2X COUNTERSUNK M3 OR #6 (NOT INCLUDED)

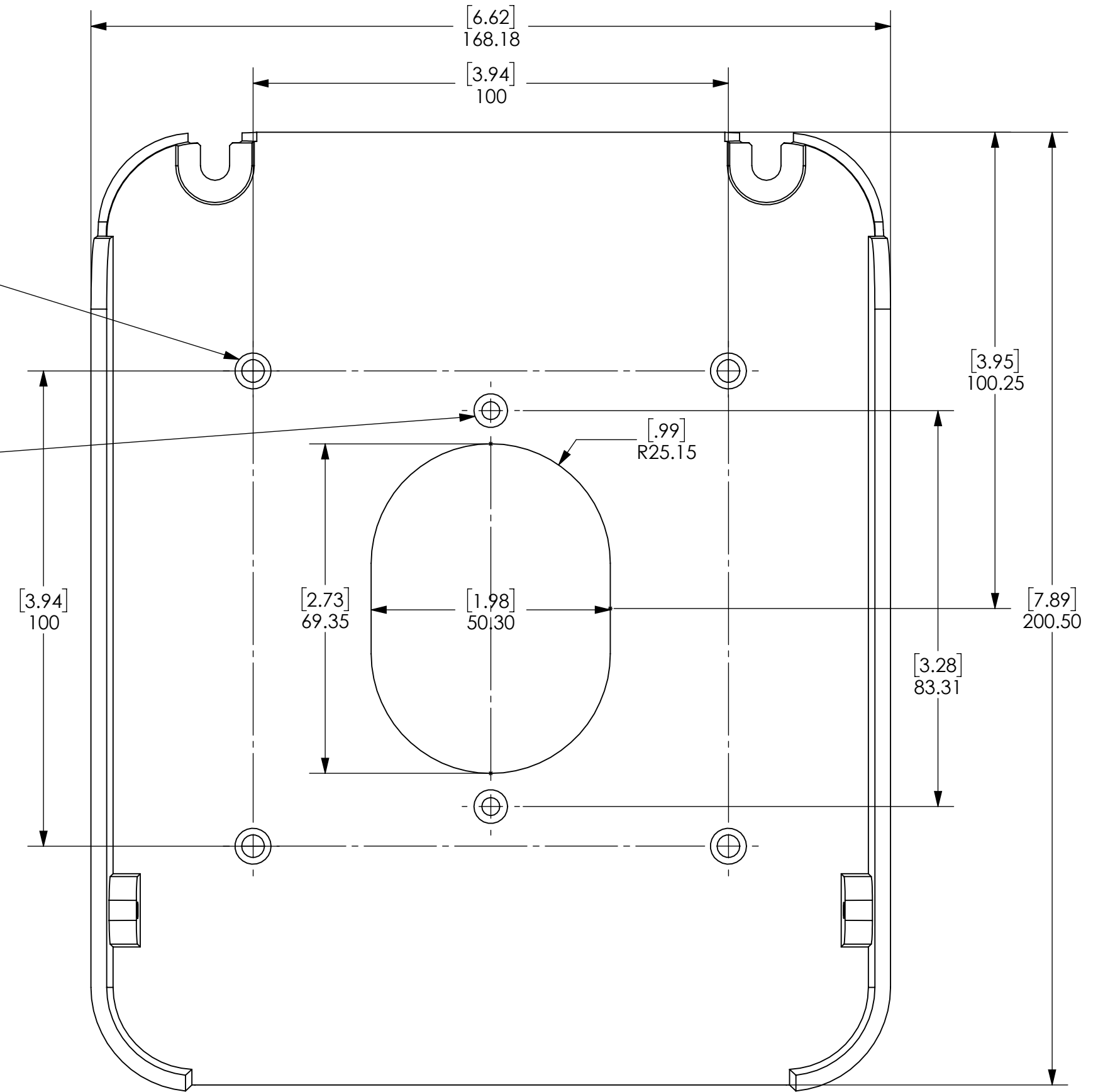

AS VIEWED FACING THE WALL

UNLESS OTHERWISE SPECIFIED, WHEN SPECIFIED DIMENSIONS ARE IN INCHES, TOLERANCES ARE: DECIMALS: X ± .03 .XX ± .01 .XXX ± .005 ANGLES: ± 1°		UNLESS OTHERWISE SPECIFIED, WHEN SPECIFIED DIMENSIONS ARE IN MM, TOLERANCES ARE: DECIMALS: X ± .25 .X ± .13 DO NOT SCALE DRAWING		300 HORIZON DRIVE, SUITE 304 HAMILTON NJ, 08691 (609)-256-6994	
DO NOT SCALE DRAWING		APPROVALS		TITLE	
MATERIAL		DRAWN KJK		WALL PLATE, ACCESS200W	
FINISH		CHECK ---		DATE 19/04/22	
SIMILAR TO		ENGR KJK		DATE 19/04/22	
DESIGN ACTIVITY		NEPTUNE		SCALE 1:1	
CAGE CODE		7Q044		DWG NO. 1000-1698	
ACT. WT.		CALC. WT.		SHEET 1 OF 1	

THIS DOCUMENT IS EXCLUSIVE PROPERTY OF PRINCETON IDENTITY AND MAY NOT BE REPRODUCED BY ANY MEANS WITHOUT PERMISSION.

4

3

2

1

DWG NO. 1000-1698 SH 1 REV. C